

## Fail Safe

- Fail-safe (power to lock) electric lock
- Use with bracket for different installation to see fit
- Power input DC12V, it is also to be used with voltage lower than DC12V
- Strong holding force. DC3V is able to obtain 15kg holding force
- Low power consumption with high efficiency noise-free
- Operation current: 150mA / 12VDC
- Holding force (Max) : 143lbs (65Kg) / DC 12V
- Operation environment : Tempt. 0-80°C
- Humidity : 85%Rh max
- Dimentions : Body : 60 (L)x38(W)x25(D)mm  
Strike plate : 60(L)x38(W)x11(D)mm
- Weight: 635g
- Certification: CE

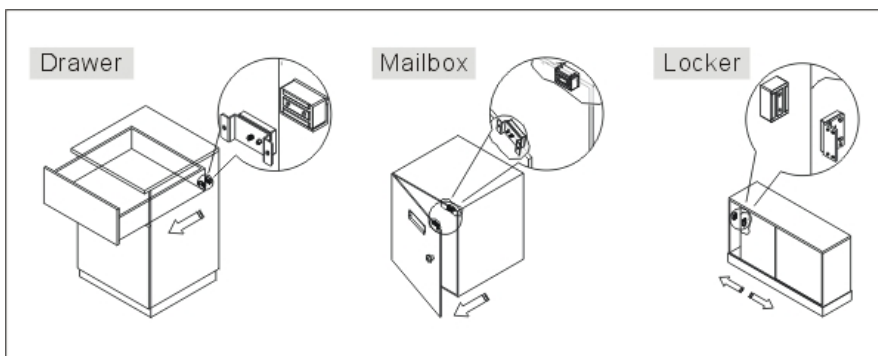
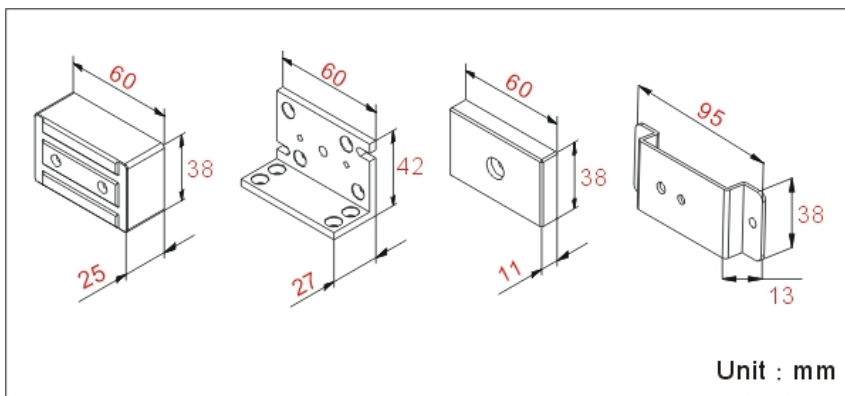

# VandalVeto®