

GL-200/220 Gate lock Series



- Fail Safe type
Stainless steel case suitable for outdoors
- Door position detection output
to detect if it is locked correctly
- Automatic demagnetizer function.
- High efficiency with low consumption of power
- Optional bracket available to install
- Operation temperature: 0~90°C; Humidity: 85%Rh max.
- Power supply: DC 12V or DC 24V
- Current: 500mA @ 12V or 250mA @ 24V
- Holding force: **GL-200** 250kg (600lbs)
GL-220 500kg(1200lbs)

- Dimensions: Lock Body: **GL-200Series** : 205(L) x 42(W) x 29(D) mm
GL-220Series : 20(L) x 63(W) x 41(D) mm

Armature: **GL-200Series** : 185(L) x 38(W) x 11mm(D)
GL-220Series : 187(L) x 60(W) x 16mm(D)

- Weight : **GL-200** 2300g
GL-220 4850g

- Certification: UL

VandalVeto®

GL-200

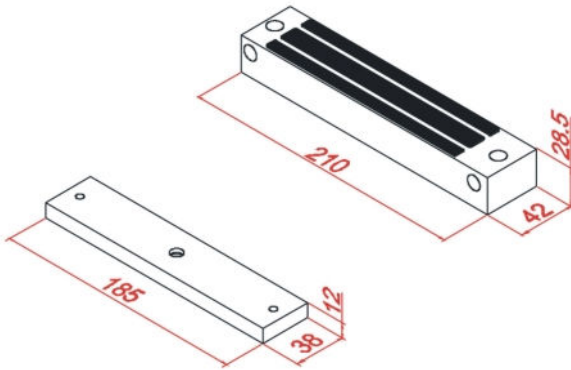

GL-200P

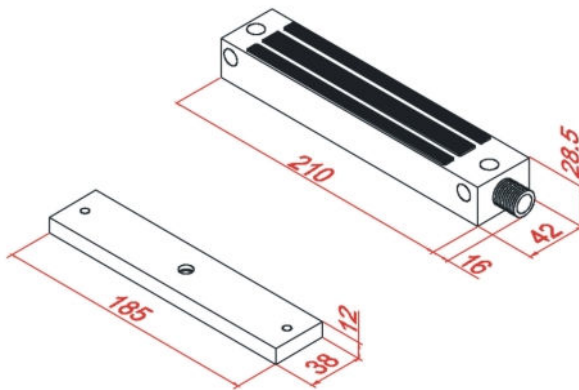

GL-220

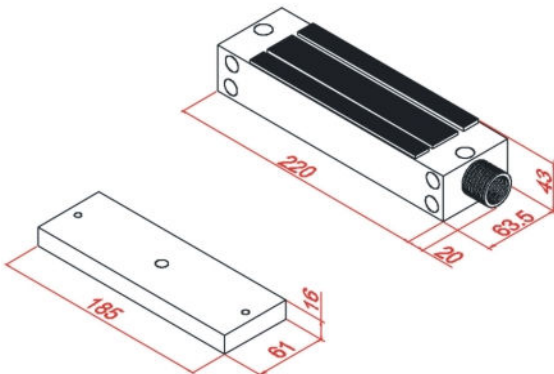

GL-220 Installation diagram

[SWING GATE]

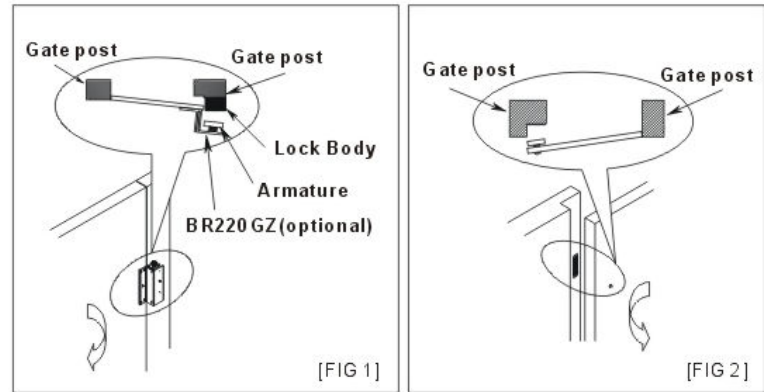

[SLIDING GATE]

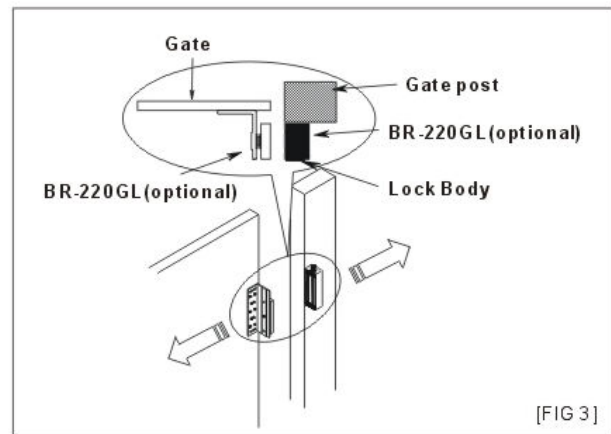

VandalVeto®