

Ports PoE Fast Unmanaged Ethernet Switch 16

700534

802.3af/at 6KV Lightning Protection Support PoE Management

VandalVeto®



- Provide 16*10/100Base-TX downlink PoE Ethernet ports, 2*10/100/1000Base-T uplink Ethernet ports and 1*1000Base-X/SFP;
- Downlink Ethernet ports support PoE+, each port supports max. 30W output;
- Support power consumption indication(LED indicates power output status); support manage PoE on/off and power consumption setting via Web;
- Accord with IEEE802.3, IEEE802.3u, IEEE802.3ab, IEEE802.3 af/at standard;
- 4K MAC address,2.75Mb cache;
- Quick installation, easy operation, convenient for wall-mounted, desktop and rack installations.



Introduction

The 16 ports PoE switch is an unmanaged PoE Ethernet switch along with 16 * 10/100Base-TX downlink PoE ports and 2 * 10/100/1000Base-T uplink Ethernet ports featuring 30-watt 802.3at PoE+ as well as 1 additional Gigabit Combo port. The total PoE power budget is up to 270 watts. It supports web-based PoE management and real-time PoE output LED display.The device can be widely used in video security monitoring systems, network projects, etc.

Application

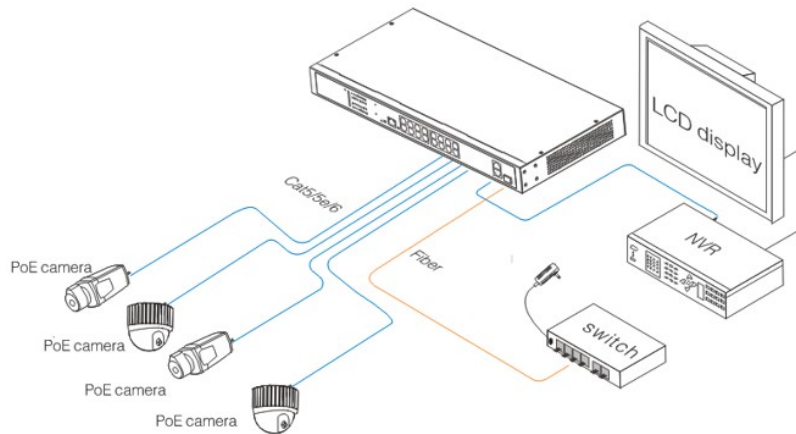

Physical Features

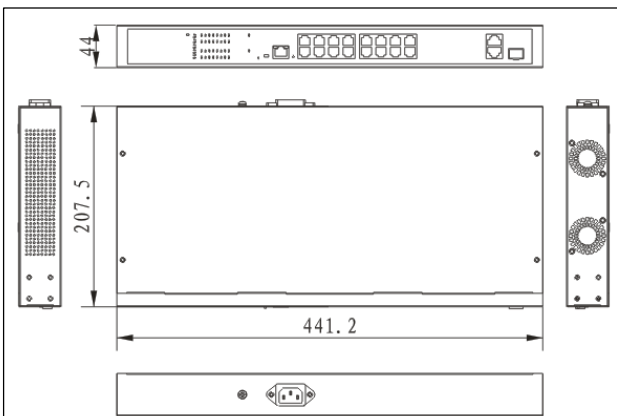

Interface drawing

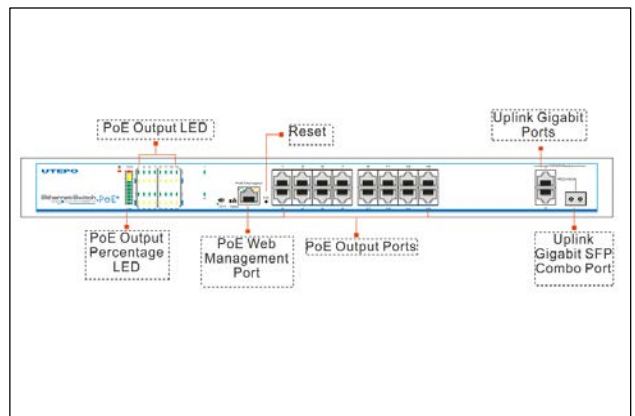

Specification

Downstream Ports	16* 10/100Base-TX(PoE)
Uplink Ports	2*10/100/1000Base-T and 1*1000Base-X/SFP(Combo)
Network Standard	IEEE802.3 、 IEEE802.3u、 IEEE802.3ab、 IEEE802.3z、 IEEE802.3X
Switch Capacity	7.2Gbps
Throughput	5.36Mpps
Switch Processing Scheme	Store and Forward
Memory Buffer	2.75M
MAC Table	4K
PoE Standard	802.3af/at(PSE)
PoE Type	End-span
Power Pin Assignment	1/2(+), 3/6(-)
PoE Power Output	54V DC , 30 watts max
PoE Budge	270 watts max
PoE Management	Via Web(Default IP Address 192.168.1.200) to check, on/off and adjust each port PoE output
Lightning protection	6KV Execute : IEC61000-4-5
ESD	6KV Contact discharge 8KV Air discharge Execute : IEC61000-4-2
Power Supply	100~240V AC; 50/60Hz
Power Dissipation	<300W(Including PoE)
Work temperature	-10°C~50°C
Storage temperature	-40°C~85°C
Humidity(Non-condensin)	5%-95%
Dimension (L×W×H)	442mm×207mm×44.5mm
Weight	2.69kg
Regulator	CE、 FCC、 ROHS

VandaVeto®

5Korazin st., Givatayim 53583 Israel
 Tel: 972-3-5713004 Fax: 972-3-5711450
 www.egber.com egber@egber.com